

# instructional support

Enhancing Teaching and Learning through Technology

## Minolta Slide Scanner with DiMAGE Scan Dual4Utility Software

### Setup procedures for scanning slides

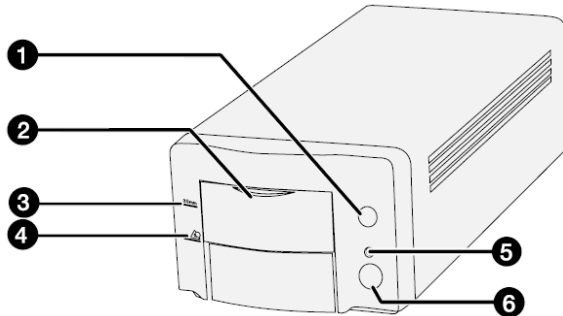

1. Eject button
2. Front door
3. Mark of 35 mm Film
4. Mark of APS cassette
5. Indicator lamp
6. Power switch



1. Turn on **Power button** on the scanner (bottom push button) and scanner door must be closed.
2. Click on **Start menu → All Programs → DiMAGE Scan Dual4 → DiMAGE Scan Dual4 Utility**. This will warm up the slide scanner and can take awhile. The screen that appears will read "Setting Up". When the setup is complete the "scanner work" screen will appear.
3. Load four slides in the slide carrier. (A single slide must also use holder)



Position the slide – landscape format



Insert from this side

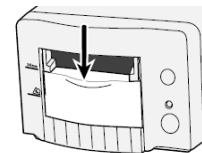

4. Open scanner door (purple) by sliding it down to the 35mm position, first notch.
5. Position the slide holder so that the **arrow side is facing up**. Insert the slide carrier into the slot. The scanner will take hold automatically and position properly. **DO NOT force in carrier** (1 slide is inside, 3 slides are outside of scanner).



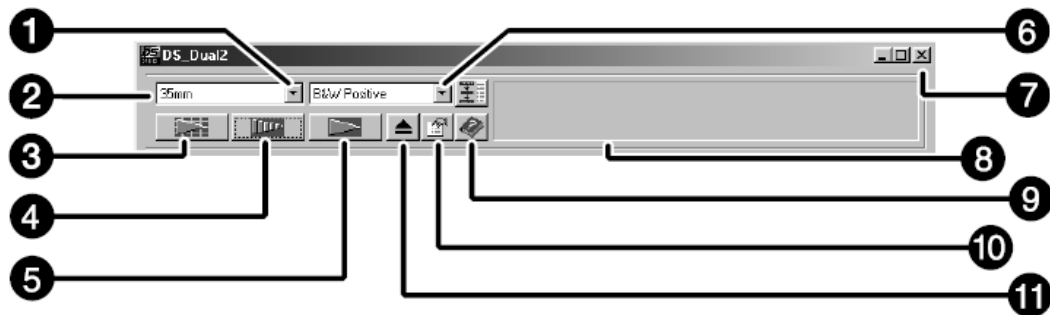

1. Film Type list box
2. Film format list box
3. Index Scan button
4. Prescan button
5. Scan button
6. Navigation button
7. Close button
8. Status bar
9. Help button
10. Preferences button
11. Eject button

6. Select settings at the top of the Menu screen as indicated below:

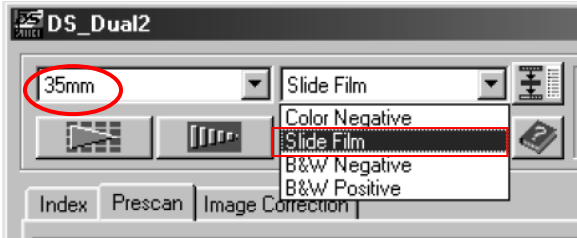

Click on Index tab to change the Resolution, default: 800dpi (lowest: 320dpi, highest: 3200dpi).  
 Click on Exposure control tab to adjust exposure setting.

*If you don't know what each button is for, when you put the mouse over the button, information will be display here.*

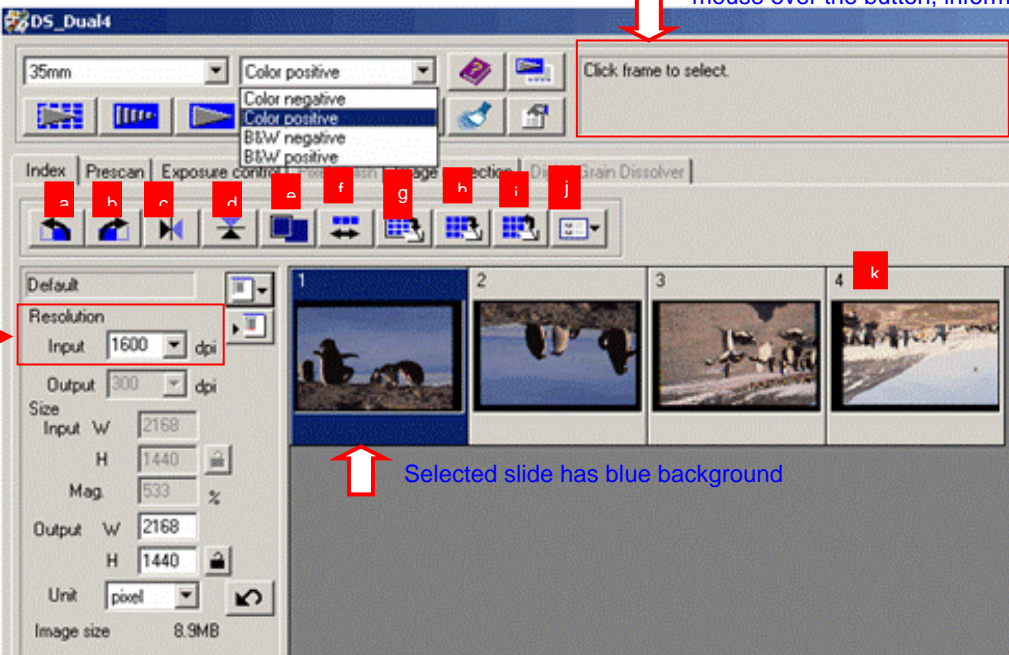

- a. Rotate left button
- b. Rotate right button
- c. Flip horizontal
- d. Flip vertical
- e. Full-screen view
- f. Reverse frame order
- g. Save Index scan
- h. Index Load
- i. Save Index Image
- j. Image Correction Job Load
- k. Frame number
- l. Index Image area

**Note:** The best way to enhance your final result is by using other software, such as Photoshop Elements.

7. For multiple images, select the “**Index Scan**” icon.  The scanner will scan all slides and create previews.  
To cancel scanning, press the “Esc” key on the keyboard.

8. Choose the slide that you want to scan by clicking on it and hit “**Pre Scan**” icon.  The scanner will *pre-scan* the slide and will be ready to do the final scan and save the digital image on your hard drive **or** you can apply some **Image Correction** before that. Prescanning creates a scan of the image that you can apply and view color, contrast, orientation, and brightness corrections before clicking on the Scan button. This ensures that final scan will be the best it can be. Click on the Prescan tab to select your settings.

### Cropping or Enhancing the Image before final scanning

9. Select the image you want to work with then go to the “Image Correction” tab.

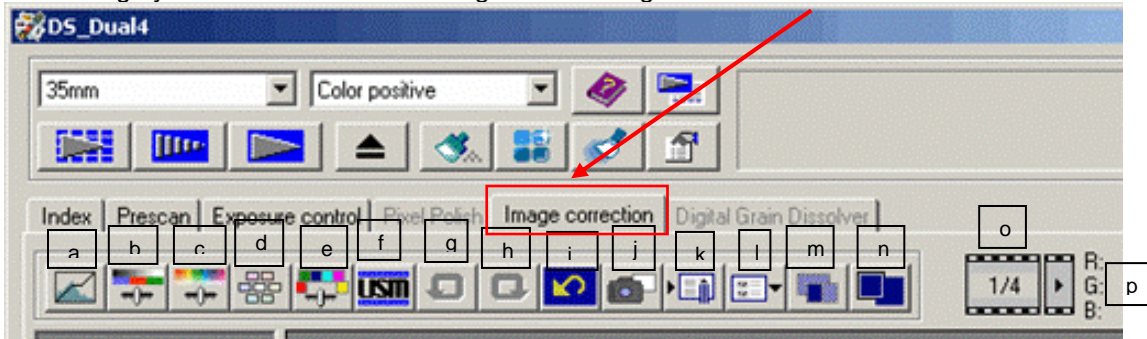

- a. Tone Curves/Histogram Correction
- b. Hue/Saturation/Lightness Correction
- c. Brightness/Contrast/Color Balance Correction
- d. Variations Corrections button
- e. Selective-color Corrections
- f. Unsharp Mask
- g. Undo button
- h. Redo button

- i. Correction Reset
- j. Snapshot button
- k. Image Correction Job Save
- l. Image Correction Job Load
- m. Pre/Post Correction Comparison Display
- n. Full-screen View
- o. Frame Number Indicator
- p. RGB value display

This will open the image in a larger view for easier manipulation with the enhancement tool bar displayed.

10. Use the enhancement tools to adjust brightness or color as needed. When the image is to your liking, **SAVE** the image by clicking on the “**Make Final Scan**” icon. 

11. Name your file and select a format (jpeg, bitmap, or tiff.) jpeg format is the best choice.

Select the amount of compression you want:

**LOW** = best quality but large file size

**MEDIUM (default)**

**HIGH** = less quality but small file size

Navigate where you would like to save your image, then click on **Save** button.

12. When you are finished scanning, eject the slide carrier by pressing

the “**Eject**” button on the menu bar  or the eject button on the front of the scanner. **Exit** from DiIMAGE software.

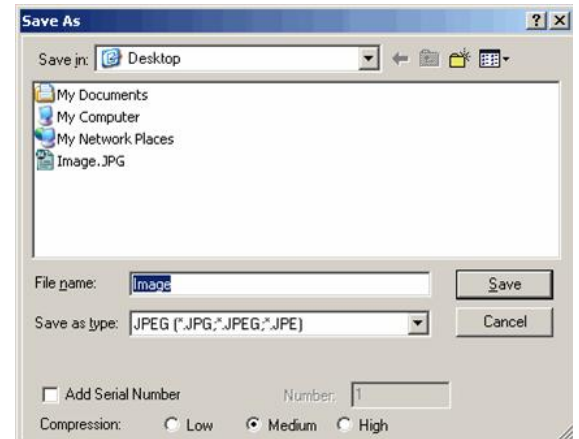

13. **Close scanner door and turn power off.**