

9.7 Cylindrical & Spherical Coordinate Systems

Exploration: In \mathbb{R}^2 , we typically use either Cartesian or Polar coordinates. So far, we have used an analog of Cartesian coordinates. Now, we will expand on Polar coordinates with two different systems.

9.7.1 Cylindrical Coordinates

Cylindrical Coordinates

We identify every points by the ordered triple (r, θ, z) , where r and θ are the polar coordinates of the projection of P onto the xy -plane, and z is the directed distance from the xy -plane. That is, to navigate to P , we begin at the origin, rotate to point in the direction of P , move directly underneath or above P , and then raise or lower to the point P .

Exploration: <https://www.geogebra.org/classic/X3j28ZkC>

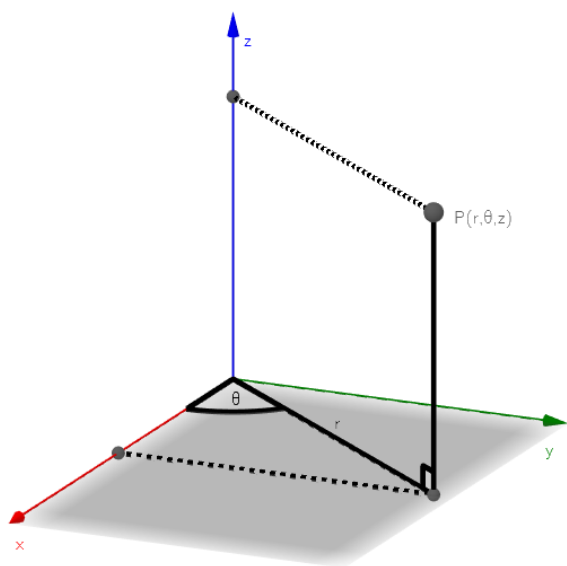

Cylindrical \rightarrow Rectangular

$$x = r \cos \theta$$

$$y = r \sin \theta$$

$$z = z$$

Rectangular \rightarrow Cylindrical

$$r^2 = x^2 + y^2$$

$$\tan \theta = \frac{y}{x}$$

$$z = z$$

Example 1. Draw a set of coordinate axes for \mathbb{R}^3 . Convert the rectangular point $P(-\sqrt{2}, -\sqrt{2}, 1)$ to cylindrical coordinates, and plot P on your axes.

Example 2. Draw a set of coordinate axes for \mathbb{R}^3 . Convert the cylindrical point $Q\left(4, \frac{5\pi}{6}, -3\right)$ to rectangular coordinates, and plot Q on your axes.

Exercise 1. Draw a set of coordinate axes for \mathbb{R}^3 .

- a. Convert the rectangular point $P(\sqrt{3}, -1, 2)$ to cylindrical coordinates, and plot P on your axes.
- b. Convert the cylindrical point $Q\left(4, \frac{2\pi}{3}, -1\right)$ to rectangular coordinates, and plot Q on your axes.

Example 3. Describe the surface whose equation is given.

- a. $z = r$
- b. $\theta = \frac{\pi}{6}$

Exercise 2. Describe the surface whose equation is given.

- a. $r = 2$
- b. $\theta = 1$

Example 4. Find an equation for the quadric surface $4x^2 + 4y^2 - z = 0$ in cylindrical coordinates. What kind of a quadric surface is this?

Exercise 3. Classify the quadric surface $3r^2 - 4z^2 = 0$ in cylindrical coordinates.

9.7.2 Spherical Coordinates

Spherical Coordinates

We identify every point by the ordered triple (ρ, θ, φ) , where we first rotate along the xy -plane a directed angle of θ , then rotate downward from the z -axis an angle of φ , then travel a distance of ρ to the point P . Note that $\rho \geq 0$ and $0 \leq \varphi \leq \pi$.

Exploration: <https://www.geogebra.org/classic/P2RQ7SRz>

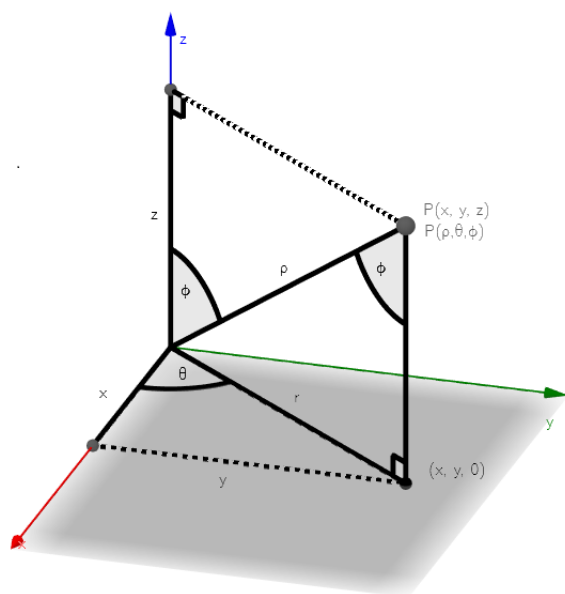

Spherical \rightarrow Rectangular

$$x = \rho \sin \varphi \cos \theta$$

$$y = \rho \sin \varphi \sin \theta$$

$$z = \rho \cos \varphi$$

Rectangular \rightarrow Spherical

$$\rho^2 = x^2 + y^2 + z^2$$

$$\cos \varphi = \frac{z}{\rho}$$

Example 5. Draw a set of coordinate axes for \mathbb{R}^3 . Convert the spherical point $P\left(4, \frac{\pi}{3}, \frac{\pi}{4}\right)$ to rectangular coordinates, and plot P on your axes.

Example 6. Draw a set of coordinate axes for \mathbb{R}^3 . Convert the rectangular point $Q(0, 2\sqrt{3}, -2)$ to spherical coordinates, and plot Q on your axes.

Exercise 4. Draw a set of coordinate axes for \mathbb{R}^3 .

- a. Convert the spherical point $P\left(1, \frac{\pi}{4}, \frac{3\pi}{4}\right)$ to rectangular coordinates, and plot P on your axes.
- b. Convert the rectangular point $Q(-1, 1, -\sqrt{2})$ to spherical coordinates, and plot Q on your axes.

Example 7. Given the spherical equation $\rho = \sin \theta \sin \varphi$, find a rectangular equation for the surface and identify the surface.

Exercise 5. Given the spherical equation $\rho^2 \sin^2 \varphi - \rho^2 \cos^2 \varphi = 1$, find a rectangular equation for the surface and identify the surface.