

Learning Cycle Planner

Solar Cooker Pringles Can Lesson

Common Curriculum Goal:

Topic: Energy efficiency, and alternative energy

Learning Objective: Hands-on experience utilizing solar energy. Stepping stone to usable renewable energy technologies.

Exploration Phase:

Hands-on Activity: Solar Cooker: Pringles Can Cooks a Hotdog
(materials and procedure below)

Exploration through Media: National Geographic Videos watch Solar Cooking and Solar Power: <http://video.nationalgeographic.com/video/player/environment/energy-environment/solar-power.html>

Concept Development Phase:

Concepts to be taught: energy conversion, heat transfer: radiation, convection, conduction; reuse, residential energy use

Procedures to be taught: Inquiry, experimental design, cooking, how to insulate

Activities: Extension: 1. Use artificial light 2. Build your own solar cooker at home: <http://solarcookers.org/programs/educres.html>

Connections to other Lessons:

Environmental justice and Women's studies- clean, renewable energy technology and resources to developing countries and poor populations

Teaching across the Curriculum:

Women's studies, environmental justice (as above)

Solar Cooking Pringles Can Experiment

Adopted from (Energy Information Administration, 2001)

Allow 45 minutes for full activity and discussion.

Materials

1 Pringles can for every 3-4 students, 1 hot dog (soy pups) for each student, plastic wrap, masking tape, 14" wood skewer for each Pringles can, scissors or sharp knife, access to direct sun.

Procedure

1. Cut the Pringles can as shown in Diagram 1. Bend back the flaps, but do not remove them from the can.
2. Cover the opening on the inside of the Pringles can with plastic wrap and tape the plastic wrap in place.
3. Make small holes in the metal end of the can and in the plastic lid. Remove the plastic lid from the can.
4. Put a hot dog onto a skewer, slide the skewer into the can, and place the end of the skewer into the hole in the metal end. Put the plastic lid back onto the can, fitting the other end of the skewer through the hole. The hot dog should be suspended inside the can as in Diagram 2.
5. Place the solar cooker in direct sunlight, positioning the flaps to reflect the maximum amount of radiant energy onto the hot dog.
6. Record the amount of time required to cook the hot dog. Consider insulating the solar cooker to improve efficiency.
7. Compare length of cooking time between groups, discuss why differences were observed.

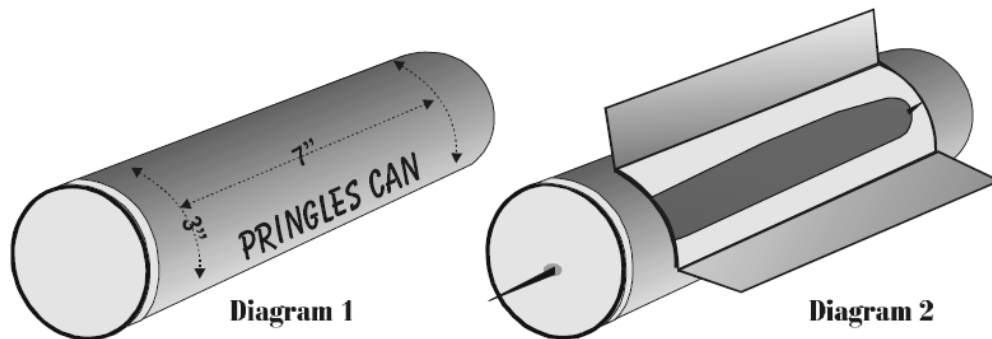

Helpful Information

Radiant energy from the sun can be reflected and concentrated on an object. A portion of the radiant energy absorbed by an object is in the form of thermal energy (heat). This is an energy conversion: radiant energy to thermal energy. Radiant energy can pass through clear materials much easier than thermal energy can.

The flaps on the Pringles can will be used to reflect radiant energy onto the hotdog, thus concentrating the amount of energy that will be converted into heat.

When positioning the flaps on the can to reflect the maximum amount of radiant energy onto the hot dog keep in mind that the angle of incidence of light equals the angle of reflection.

Extension

Try cooking a hog dog in artificial light from a projector or a heat lamp.

Extra credit /Independent study project:

Use information from <http://solarcookers.org/programs/educres.html> to build a larger solar cooker at home or at school. Successfully cooking a dish in the solar cooker and presenting the materials and processes used constitutes assessment.

References:

Energy Information Administration (2001). *Intermediate Activity Solar Cooking*.

Retrieved June 29, 2009, from

<http://www.eia.doe.gov/kids/classactivities/SolarCookingIntermediateActivity.pdf>